

The petainerKeg™ Linestar format can be filled on many suitably modified steel Keg-Fillers.
Please contact the filling machine supplier for advice, format parts and program modifications.

When using the petainerKeg™ Linestar format, please note the following:

General

Modify the machine program in accordance with the instructions below:

1. All steel Keg washing and sterilising functions need to be inhibited.
2. Keg must be filled volumetrically to the required capacity to provide head space.

Racker Conversion

1. Check that the filling head spear adaptor (piston top) dimensions comply with the Petainer closure drawing. Failure to do so may damage the closure and prevent its proper operation!
2. Maximum allowed clamp-pressure is:
 - a. 30 l Linestar: 1060 N

Filling

1. The petainerKeg™ Linestar is purged with N₂ (> 99% N₂) and counter-pressurised with ca. 0.5bar.
3. Keg counter-pressure and filling (maximum pressure 3 bar / 43.5 psi) can then proceed as normal.

Intermediate head rinsing

If the racker design allows, it is desirable to flush/disinfect the filling head and each keg valve from outside before and after filling.

1. e.g. with hot water (1 second with 85°C / 185 F).
2. Water pressure before filling maximum 0.5 bar / 7 psi.
3. Water pressure after filling should not exceed the pressure in the Keg.

Safety

1. All machinery must be guarded in accordance with local regulations.
2. Eye and ear protection, together with work-wear should be used.
3. PET Kegs can burst when damaged by sharp objects.
4. Under filled Kegs or other rejects should be de-pressurised prior to disposal.



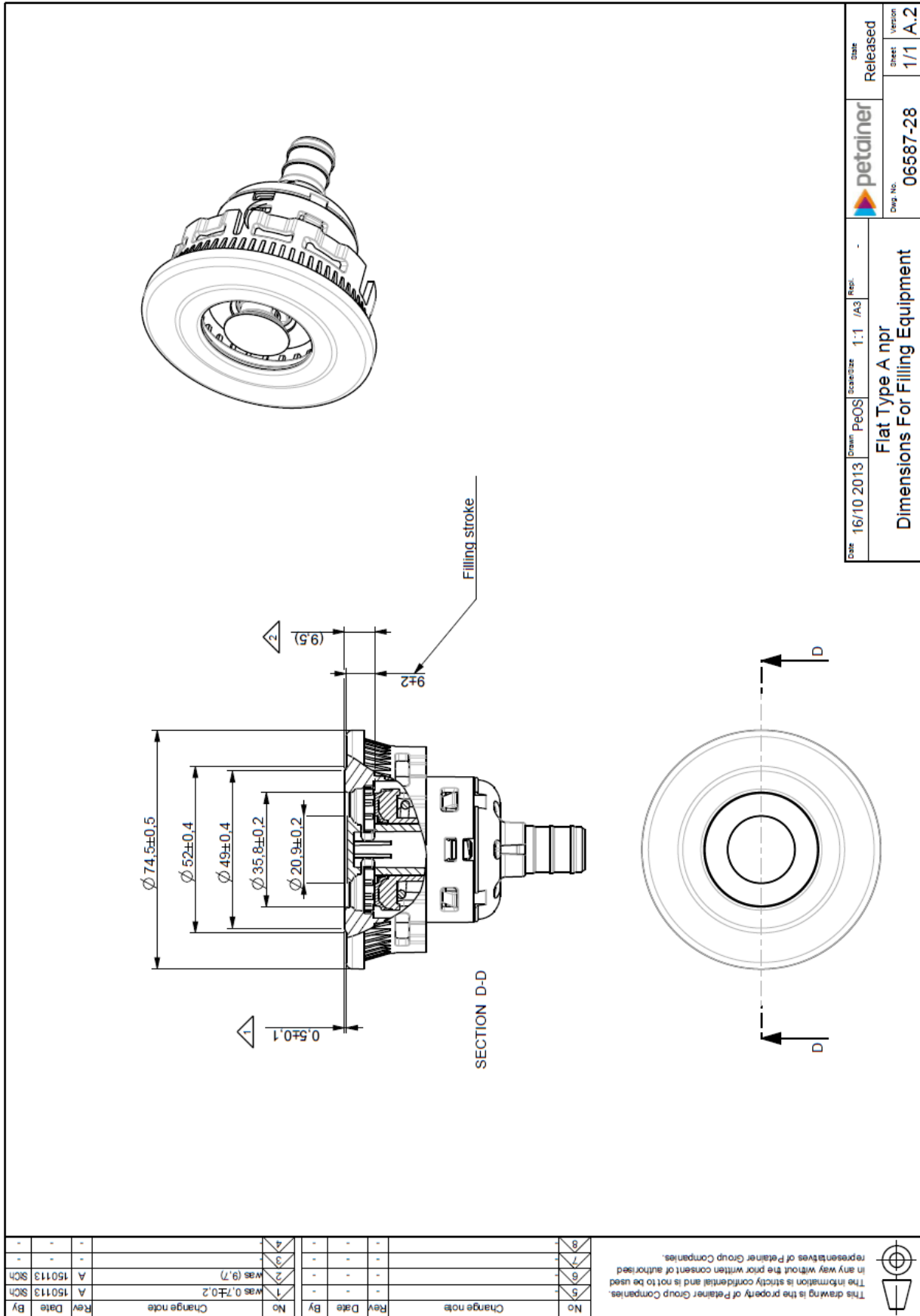

Date	16/10 2013	Drawn	PeOS	Scale/Size	1:1 /A3	Rev.	-
Released	petainer						
Sheet	06687-28						
Version	1/1 A.2						
Flat Type A npr Dimensions For Filling Equipment							

This drawing is the property of Petainer Group Companies. In any way without the prior written consent of authorized representatives of Petainer Group Companies.



